

## Montering passagerarsidan

Passagerarstol  
(original)

Kapa av de 2  
tapparna (Ø9)  
under stolsskenorna

Plan sida av  
muttern mot  
stolsskenorna

Stolsunderrede  
(original)

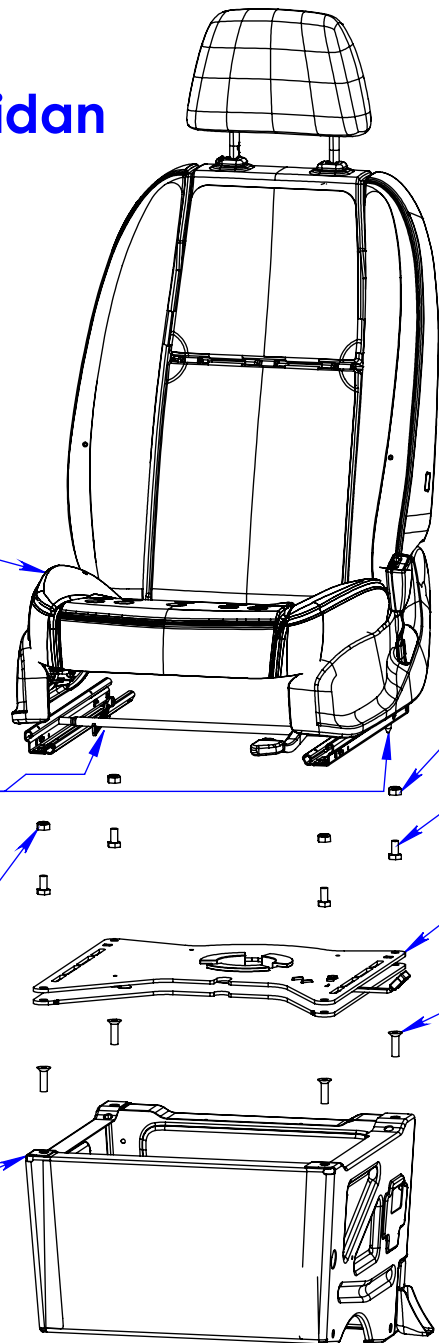

## Montering förarsidan

Förarstol  
(original)

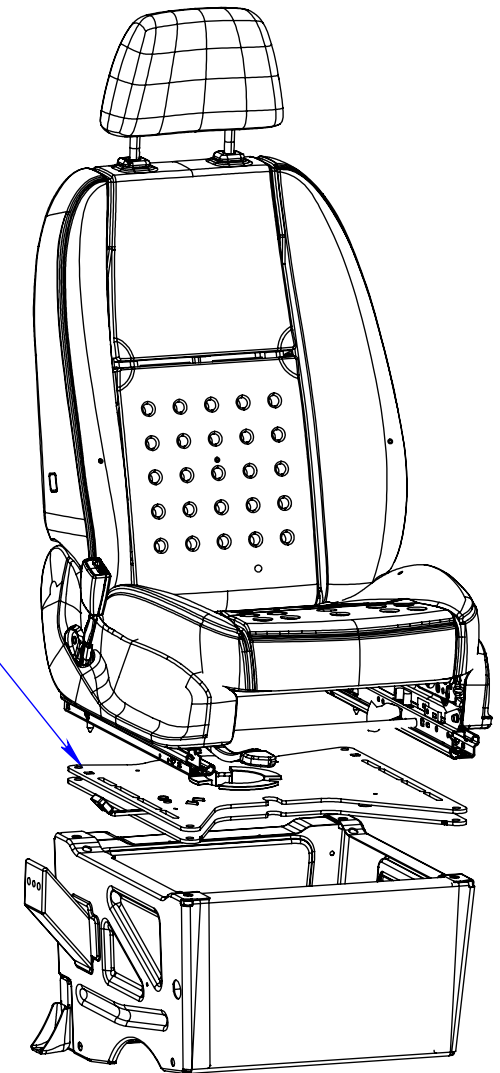

4 st M10 låsmutter

4 st M10x20 bultar  
Åtdragningsmoment: 30 Nm

Vridplatta

4 st M10x35 bultar (försänkt  
huvud).  
Åtdragningsmoment: 30 Nm

Koppla loss kontaktstycken och trä igen  
centrumhålet i vridplattan

A	Version d'origine	21/10/2019	AL
Indice	Evolution	Date	Par
<b>Révisions</b>			
		MATIERE: TRAITEMENT: -	POIDS:
		TOLERANCES GENERALES: JS11 / js11	
SCOPEMA rue du Pouloueix - 87150 Oradour-sur-Vayres - France Tel : +33 (0) 555 78 11 49 ; Fax : +33 (0)555 78 15 88 ; Web : <a href="http://www.scopema.com">www.scopema.com</a>			
Client: -	Ref: -		
Ce plan est la propriété de SCOPEMA Il ne peut être communiqué à des tiers ou reproduit sans autorisation écrite de SCOPEMA. This drawing cannot be printed or issued to anybody without SCOPEMA Authorisation			
		Ech: 1/11	A4 
		Page: 1/1	